

Service Manual

Pioneer

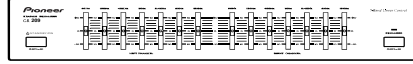

ORDER NO.
RRV2147

GRAPHIC EQUALIZER

GR-209

THIS MANUAL IS APPLICABLE TO THE FOLLOWING MODEL(S) AND TYPE(S).

Type	Model	Power Requirement	Remarks
	GR-209		
MYXCN1	○	AC220- 230V	
SDXCN1	○	AC110/120-127/220/240V	With the voltage selector

CONTENTS

1. SAFETY INFORMATION	2
2. EXPLODED VIEWS AND PARTS LIST	3
3. SCHEMATIC DIAGRAM	6
4. PCB CONNECTION DIAGRAM	8
5. PCB PARTS LIST	10
6. ADJUSTMENT	10
7. GENERAL INFORMATION	11
7.1 IC	11
8. PANEL FACILITIES AND SPECIFICATIONS	13

PIONEER ELECTRONIC CORPORATION 4-1, Meguro 1-Chome, Meguro-ku, Tokyo 153-8654, Japan
PIONEER ELECTRONICS SERVICE, INC. P.O. Box 1760, Long Beach, CA 90801-1760, U.S.A.
PIONEER ELECTRONIC (EUROPE) N.V. Haven 1087, Keetberglaan 1, 9120 Melsele, Belgium
PIONEER ELECTRONICS ASIACENTRE PTE. LTD. 253 Alexandra Road, #04-01, Singapore 159936
 © **PIONEER ELECTRONIC CORPORATION 1999**

1. SAFETY INFORMATION

This service manual is intended for qualified service technicians ; it is not meant for the casual do-it-yourselfer. Qualified technicians have the necessary test equipment and tools, and have been trained to properly and safely repair complex products such as those covered by this manual.

Improperly performed repairs can adversely affect the safety and reliability of the product and may void the warranty. If you are not qualified to perform the repair of this product properly and safely, you should not risk trying to do so and refer the repair to a qualified service technician.



WARNING

This product contains lead in solder and certain electrical parts contain chemicals which are known to the state of California to cause cancer, birth defects or other reproductive harm.

Health & Safety Code Section 25249.6 – Proposition 65



NOTICE

(FOR CANADIAN MODEL ONLY)

Fuse symbols  (fast operating fuse) and/or  (slow operating fuse) on PCB indicate that replacement parts must be of identical designation.

REMARQUE

(POUR MODÈLE CANADIEN SEULEMENT)

Les symboles de fusible  (fusible de type rapide) et/ou  (fusible de type lent) sur CCI indiquent que les pièces de remplacement doivent avoir la même désignation.

(FOR USA MODEL ONLY)

1. SAFETY PRECAUTIONS

The following check should be performed for the continued protection of the customer and service technician.

LEAKAGE CURRENT CHECK

Measure leakage current to a known earth ground (water pipe, conduit, etc.) by connecting a leakage current tester such as Simpson Model 229-2 or equivalent between the earth ground and all exposed metal parts of the appliance (input/output terminals, screwheads, metal overlays, control shaft, etc.). Plug the AC line cord of the appliance directly into a 120V AC 60Hz outlet and turn the AC power switch on. Any current measured must not exceed 0.5mA.

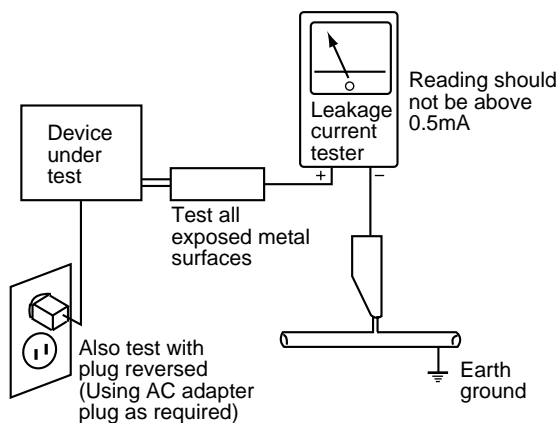

AC Leakage Test

ANY MEASUREMENTS NOT WITHIN THE LIMITS OUTLINED ABOVE ARE INDICATIVE OF A POTENTIAL SHOCK HAZARD AND MUST BE CORRECTED BEFORE RETURNING THE APPLIANCE TO THE CUSTOMER.

2. PRODUCT SAFETY NOTICE

Many electrical and mechanical parts in the appliance have special safety related characteristics. These are often not evident from visual inspection nor the protection afforded by them necessarily can be obtained by using replacement components rated for voltage, wattage, etc. Replacement parts which have these special safety characteristics are identified in this Service Manual.

Electrical components having such features are identified by marking with a Δ on the schematics and on the parts list in this Service Manual.

The use of a substitute replacement component which does not have the same safety characteristics as the PIONEER recommended replacement one, shown in the parts list in this Service Manual, may create shock, fire, or other hazards.

Product Safety is continuously under review and new instructions are issued from time to time. For the latest information, always consult the current PIONEER Service Manual. A subscription to, or additional copies of, PIONEER Service Manual may be obtained at a nominal charge from PIONEER.

2. EXPLODED VIEWS AND PARTS LIST

- NOTES:
- Parts marked by "NSP" are generally unavailable because they are not in our Master Spare Parts List.
 - The Δ mark found on some component parts indicates the importance of the safety factor of the part. Therefore, when replacing, be sure to use parts of identical designation.
 - Screws adjacent to ∇ mark on the product are used for disassembly.

2.1 PACKING

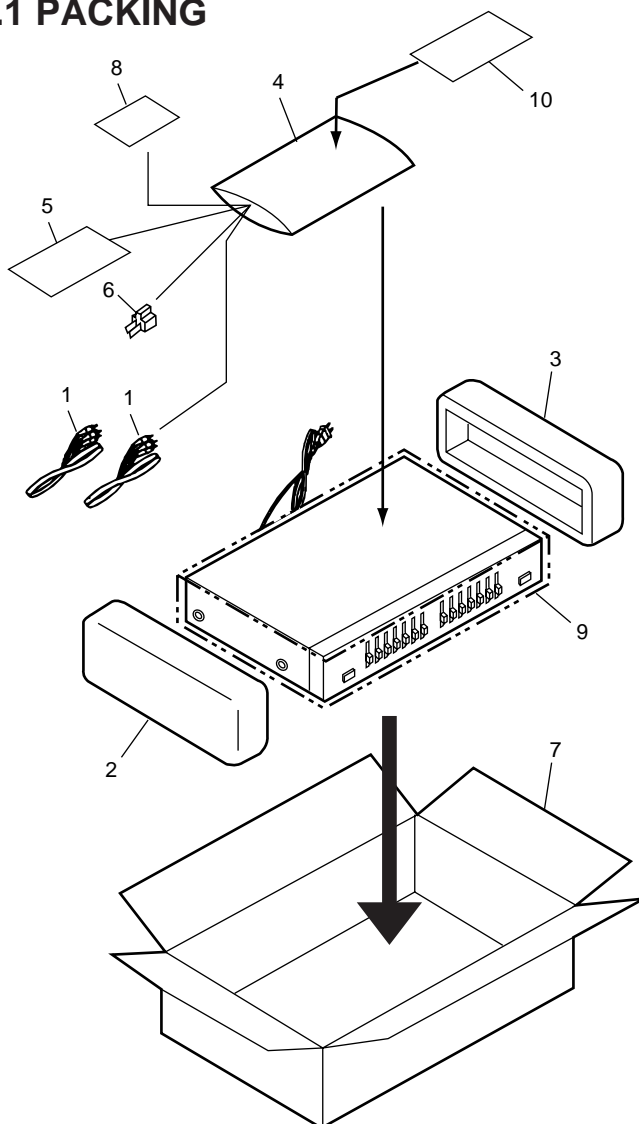

(1) PACKING PARTS LIST

Mark	No.	Description	Part No.
	1	Pin Plug Cords (L = 1m)	PDE1248
	2	Polyform L	14904081-000
	3	Polyform R	14904082-000
	4	Polyethylene Bag (0.03X230X340)	Z21-038
	5	Operating Instructions	See Contrast table (2)
	6	Power Plug Adaptor	See Contrast table (2)
	7	Carton Box	See Contrast table (2)
	8	Warranty Card	•••••
NSP	9	Packing Sheet	•••••
NSP	10	CAUTION 220V LABEL	See Contrast table (2)

(2) CONTRAST TABLE

GR-209/MYXCN1 and SDXCN1 are constructed the same except for the following:

Mark	No.	Symbol and Description	Part No.		Remarks
			MYXCN1 type	SDXCN1 type	
	5	Operating Instructions (English/French/German/Italian /Dutch/Swedish/Spanish/Portuguese)	15202090-0297	Not used	
	5	Operating Instructions (English/Spanish/Chinese)	Not used	15202091-0297	
	6	Power Plug Adaptor	Not used	VKX1007	
	7	Carton Box	15302090-0297	15302091-0297	
	10	CAUTION 220V LABEL	Not used	ARR7003	

2.2 EXTERIOR SECTION

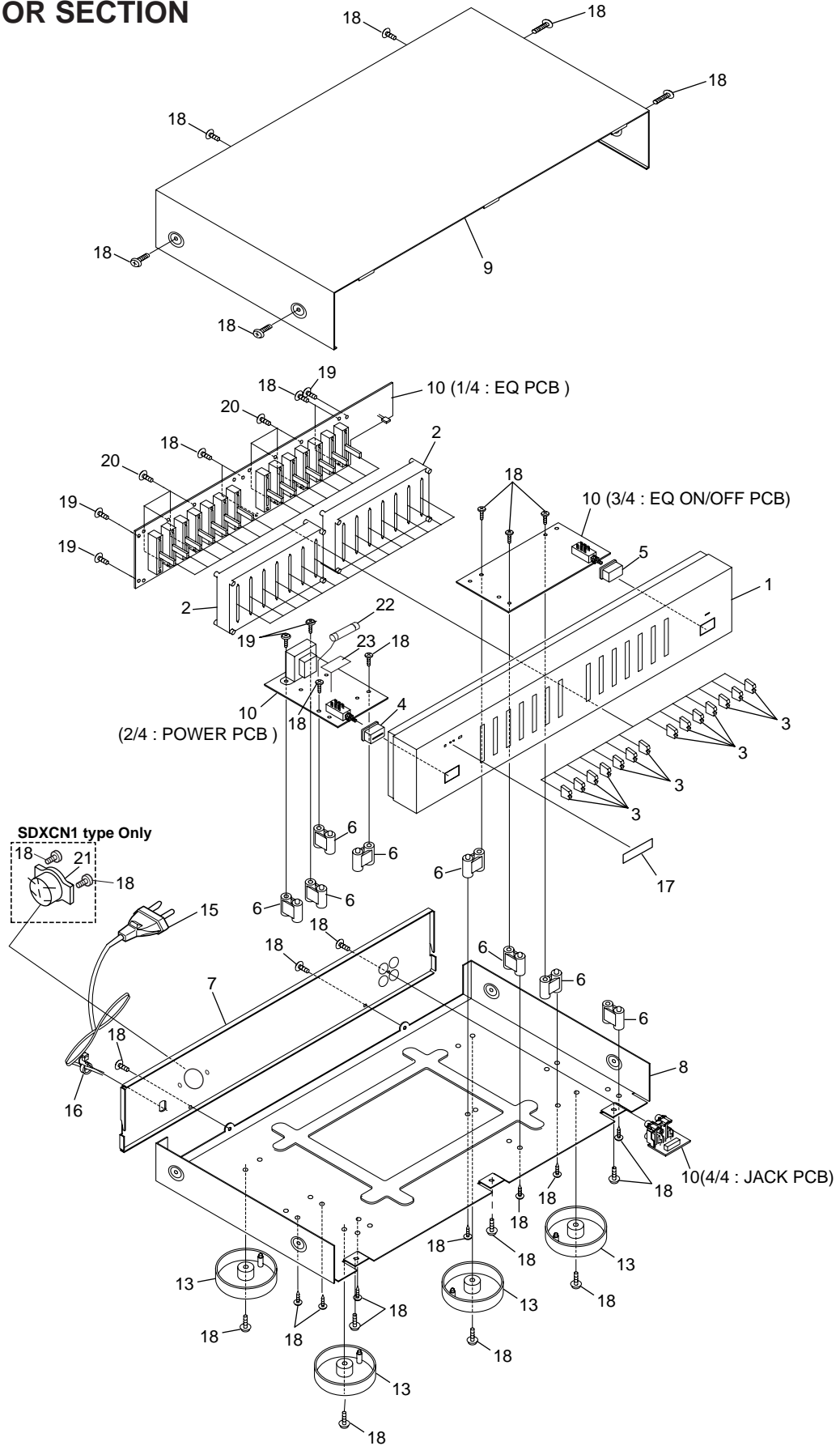

(1) EXTERIOR SECTION PARTS LIST

Mark	No.	Description	Part No.
	1	Front Cabinet	10104080-002
	2	EQ Bracket	12904082-010
	3	EQ Knob(Black)	12704082-010
	4	Power Button	12804080-010
	5	EQ On/Off Button	12804080-110
	6	Post	13004082-000
	7	Rear Panel	See Contrast table (2)
NSP	8	Bottom Cabinet	•••••
	9	Bonnet Cover	18004083-010
	10	Main Bord Assy	See Contrast table (2)
	11	•••••	
	12	•••••	
	13	Foot(Black)W/O H/S	13821007-010
	14	•••••	
⚠	15	AC Power Cord	02360020-004
NSP	16	Bushing	13000000-001
	17	Name Plate	PAM1776
	18	Screw	BBZ30P080FZK
	19	Screw	IBZ30P080FMC
	20	Screw	BPZ26P080FMC
⚠	21	Voltage Selector	See Contrast table (2)
⚠	22	Fuse (630mA/250V)	05005020-063
	23	Fuse Caution Label	15454081-003

(2) CONTRAST TABLE

GR-209/MYXCN1 and SDXCN1 are constructed the same except for the following:

Mark	No.	Symbol and Description	Part No.		Remarks
			MYXCN1 type	SDXCN1 type	
	7 10	Rear Panel Main Bord Assy	18004085-102 GR209/MY	18004085-201 GR209/SD	
⚠	21	Voltage Selector	Not used	AKX-507	

3. SCHEMATIC DIAGRAM

3.1 MAIN BOARD ASSY

A

AC220-230V 50/60Hz
MYXCN1 TYPE

AC110/120-127/
220/240V 50/60Hz
SDXCN1

AC POWER
CORD
02360020-004

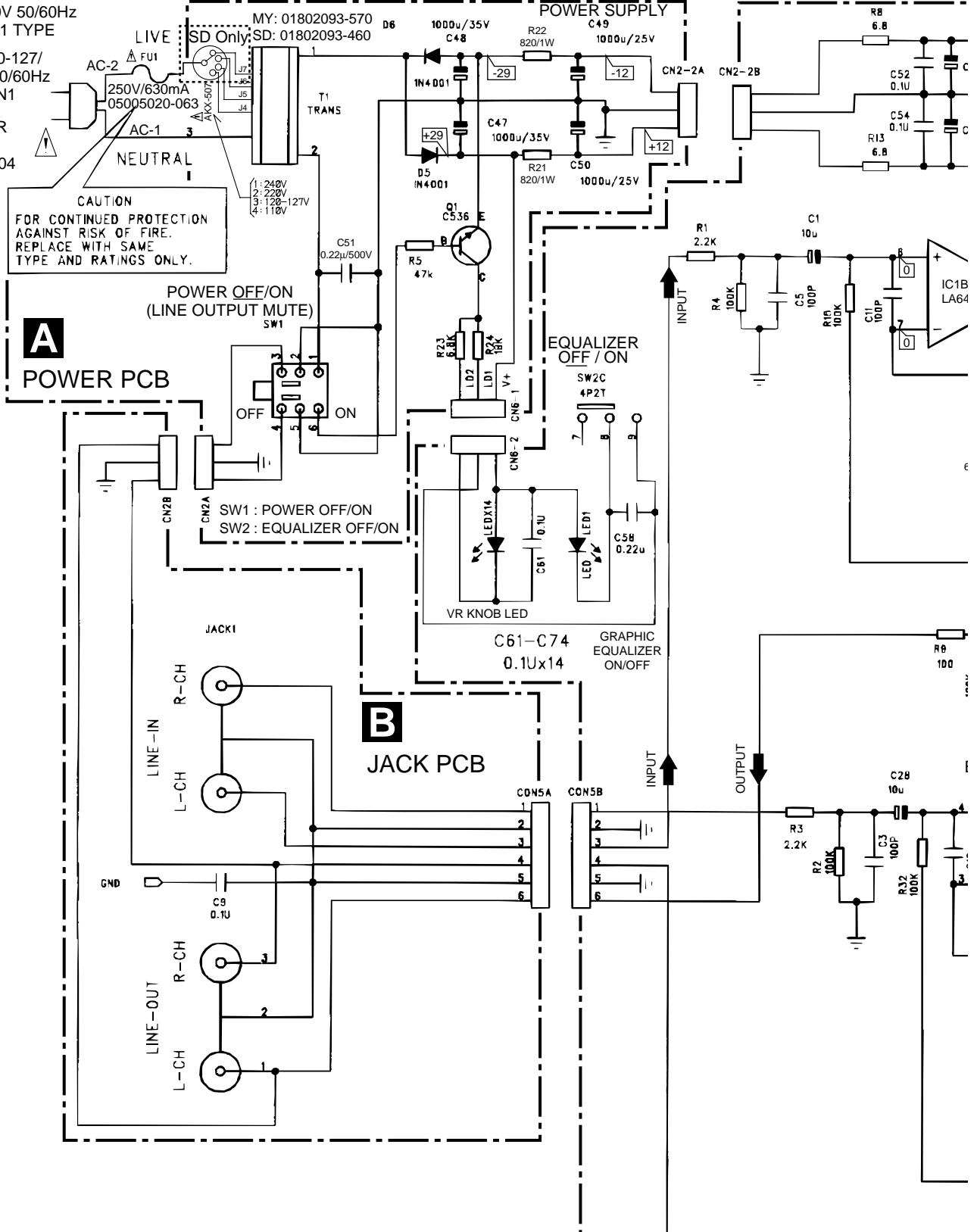

B

C

D

4. PCB CONNECTION DIAGRAM

SIDE A

4.1 MAIN BOARD ASSY

NOTE FOR PCB DIAGRAMS :

1. Part numbers in PCB diagrams match those in the schematic diagrams.
2. The parts mounted on this PCB include all necessary parts for several destinations.
For further information for respective destinations, be sure to check with the schematic diagram.
3. View point of PCB diagrams.

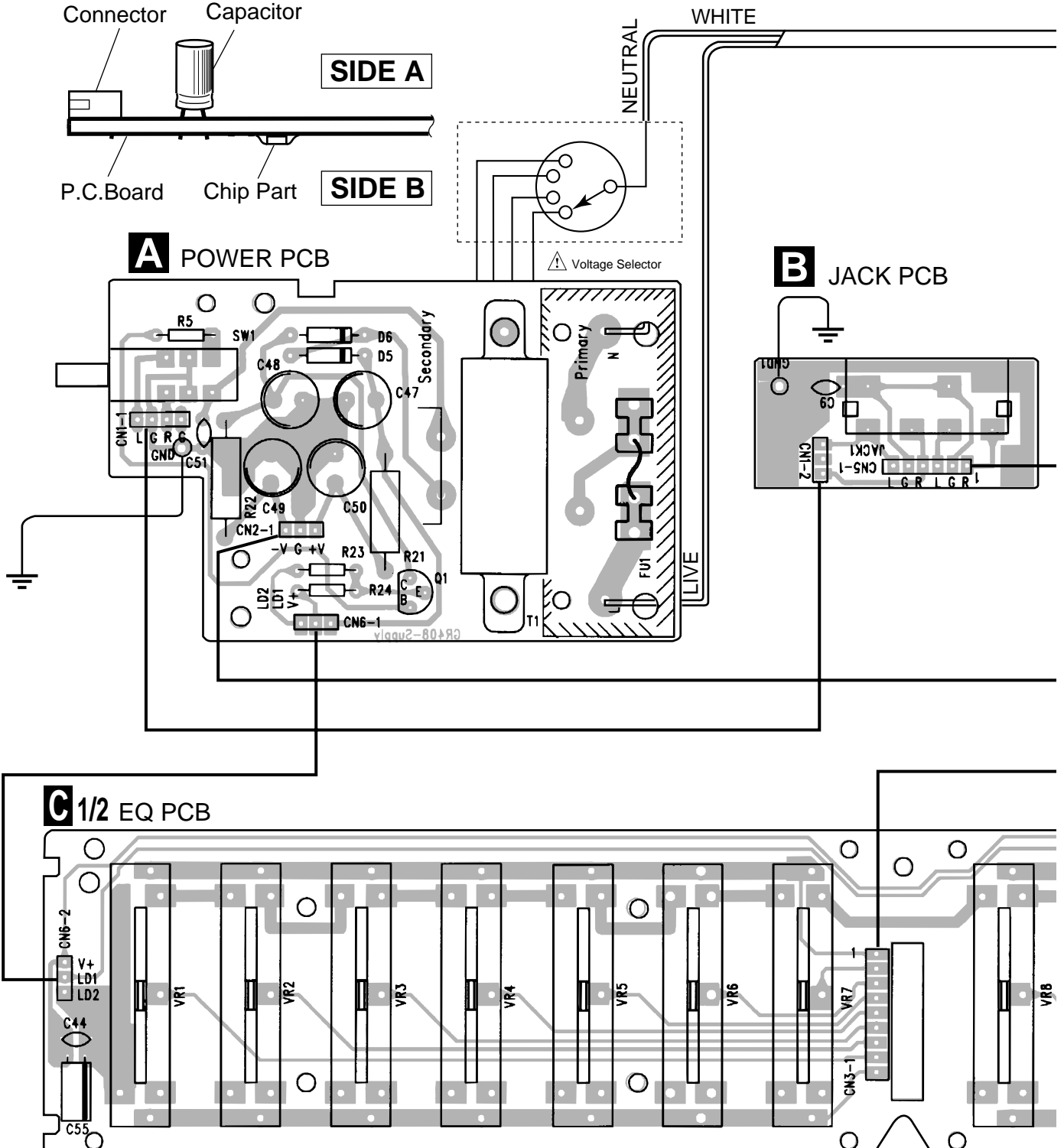
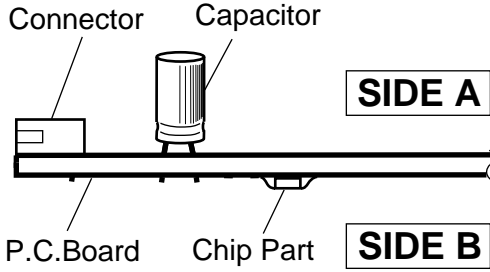

A B C

SIDE A

MAIN BOARD ASSY

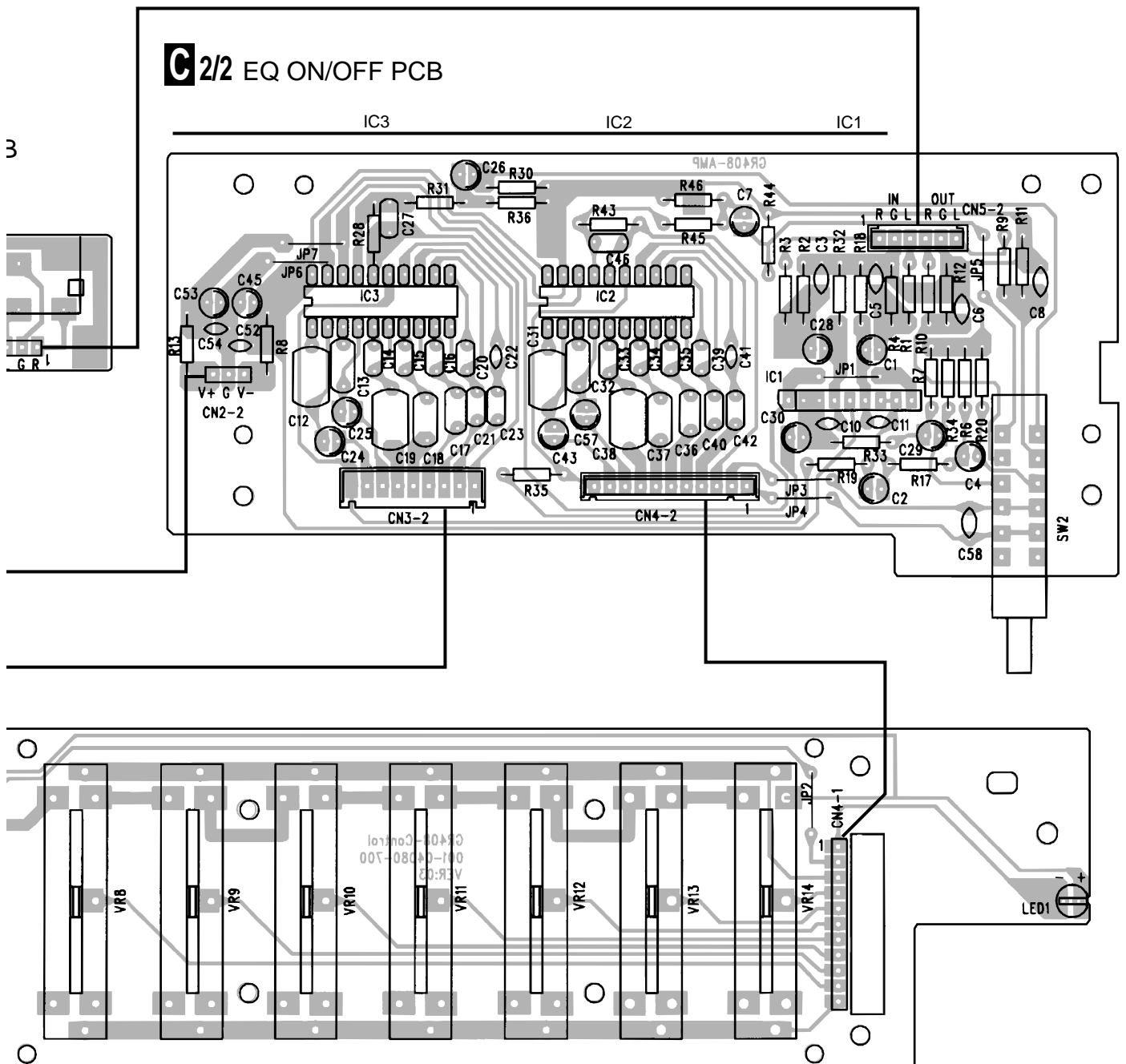
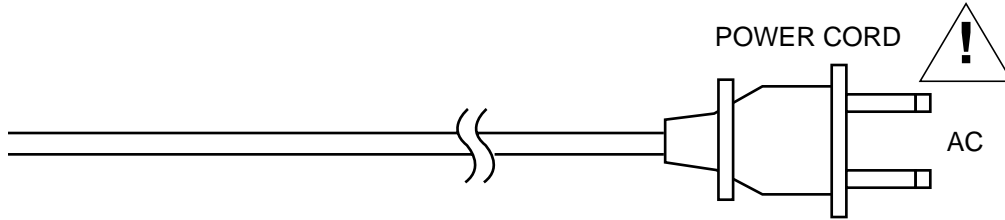

5. PCB PARTS LIST

- NOTES: ●Parts marked by "NSP" are generally unavailable because they are not in our Master Spare Parts List.
 ●The Δ mark found on some component parts indicates the importance of the safety factor of the part. Therefore, when replacing, be sure to use parts of identical designation.
 ●When ordering resistors, first convert resistance values into code form as shown in the following examples.
- Ex.1 When there are 2 effective digits (any digit apart from 0), such as 560 ohm and 47k ohm (tolerance is shown by J=5%, and K=10%).
- 560 Ω \rightarrow 56×10^1 \rightarrow 561 RD1/4PU $\boxed{5} \boxed{6} \boxed{1} J$
 47k Ω \rightarrow 47×10^3 \rightarrow 473 RD1/4PU $\boxed{4} \boxed{7} \boxed{3} J$
 0.5 Ω \rightarrow R50 RN2H $\boxed{R} \boxed{5} \boxed{0} K$
 1 Ω \rightarrow 1R0 RS1P $\boxed{1} \boxed{R} \boxed{0} K$
- Ex.2 When there are 3 effective digits (such as in high precision metal film resistors).
- 5.62k Ω \rightarrow 562×10^1 \rightarrow 5621 RN1/4PC $\boxed{5} \boxed{6} \boxed{2} \boxed{1} F$

■ LIST OF WHOLE PCB ASSEMBLIES

Mark	Symbol and Description	Part No.		Remarks
		MYXCN1	SDXCN1	
NSP	MAIN BOARD ASSY	GR209/MY	GR209/SD	
NSP	EQ PCB	
NSP	POWER PCB	
NSP	EQ ON / OFF PCB	
NSP	JACK PCB	

■ PCB PARTS LIST

MAIN BOARD ASSY

(1) CONTRAST TABLE

GR209/MY and GR209/SD are constructed the same except for the following:

Mark	Symbol and Description	Part No.		Remarks
		GR209/MY	GR209/SD	
Δ	T1 Transformer	01802093-570	01802093-460	

Mark	No.	Description	Part No.	Mark	No.	Description	Part No.
------	-----	-------------	----------	------	-----	-------------	----------

(2) PARTS LIST for GR209/MY

A POWER PCB

SEMICONDUCTORS

LED1	LED	01912000-053
------	-----	--------------

SWITCHES

Δ SW1	PBS-22H030F18	02042218-111
--------------	---------------	--------------

OTHERS

Δ T1	TRANSFORMER EI-35	01802093-570
-------------	-------------------	--------------

B JACK PCB

This unit has no service parts.

C EQ PCB

SEMICONDUCTORS

IC2,IC3	AUDIO IC	M5229P
IC1	IC LA6458SS	00206458-040

SWITCHES

SW2	PBS-42H03-F18	02014218-110
-----	---------------	--------------

RESISTOR

VR1-VR14	SLIDE VR.	01110203-230
----------	-----------	--------------

6. ADJUSTMENT

There is no information to be shown in this chapter.

7. GENERAL INFORMATION

7.1 IC

- The information shown in the list is basic information and may not correspond exactly to that shown in the schematic diagrams.

■ M5229P (MAIN BOARD ASSY : IC2, IC3)

• Graphic Equalizer

• Pin Arrangement

IN 1	1	20	-Vcc
NF 1	2	19	GND
IN 2	3	18	+Vcc
NF 2	4	17	OUTPUT
IN 3	5	16	INVERTING INPUT
NF 3	6	15	NON-INVERTING INPUT
IN 4	7	14	NF 7
NF 4	8	13	IN 7
IN 5	9	12	NF 6
NF 5	10	11	IN 6

• Block Diagram

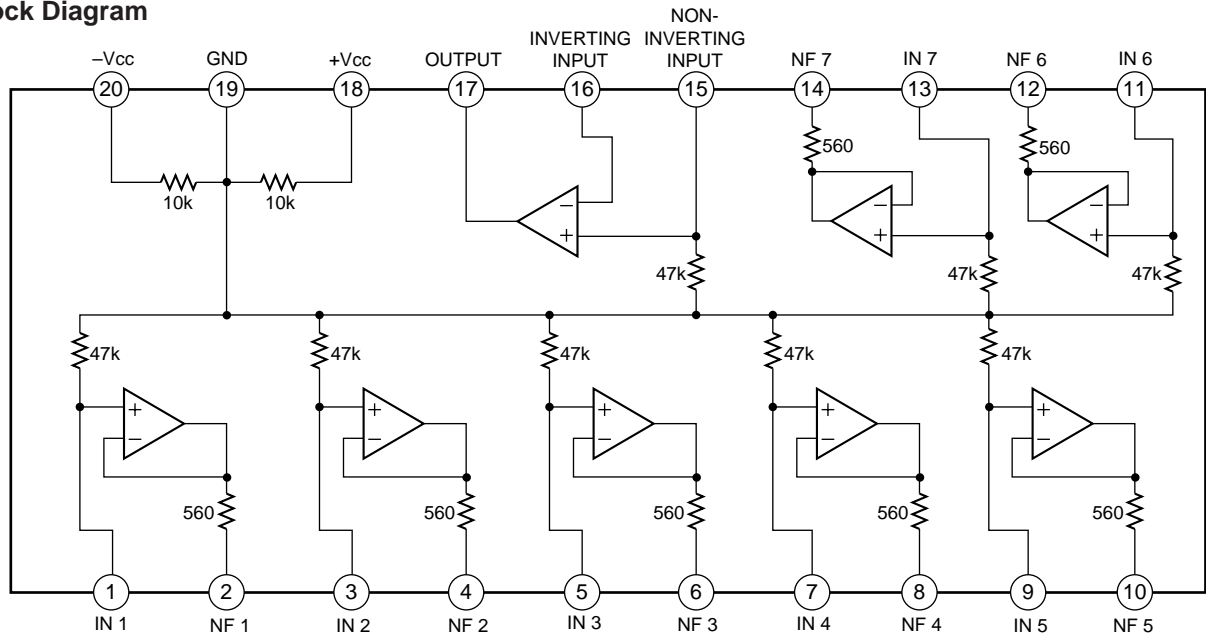

• Pin Function

No.	Pin Name	Function	No.	Pin Name	Function	
1	IN 1	Compose the bandpass filter by connecting a capacitor with IN terminals and NF terminals located next to each other, and the gain can be set up by connecting a variable resistor (slide volume).	11	IN 6	Compose the bandpass filter by connecting a capacitor with IN terminals and NF terminals located next to each other, and the gain can be set up by connecting a variable resistor (slide volume).	
2	NF 1		12	NF 6		
3	IN 2		13	IN 7		
4	NF 2		14	NF 7		
5	IN 3		15	Non-inverting input		Non-inverting input pin for output OP amp.
6	NF 3		16	Inverting input		Inverting input pin for output OP amp.
7	IN 4		17	OUTPUT		Output pin for output OP amp.
8	NF 4		18	+Vcc		Positive power supply pin
9	IN 5		19	GND		Ground pin
10	NF 5		20	- Vcc		Negative power supply pin

■ LA6458S (MAIN BOARD ASSY : IC1)

- Input Buffer Amplifier

● Pin Arrangement

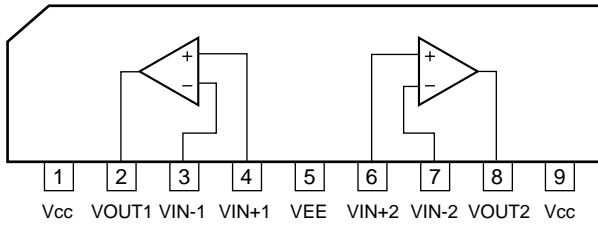

● Block Diagram

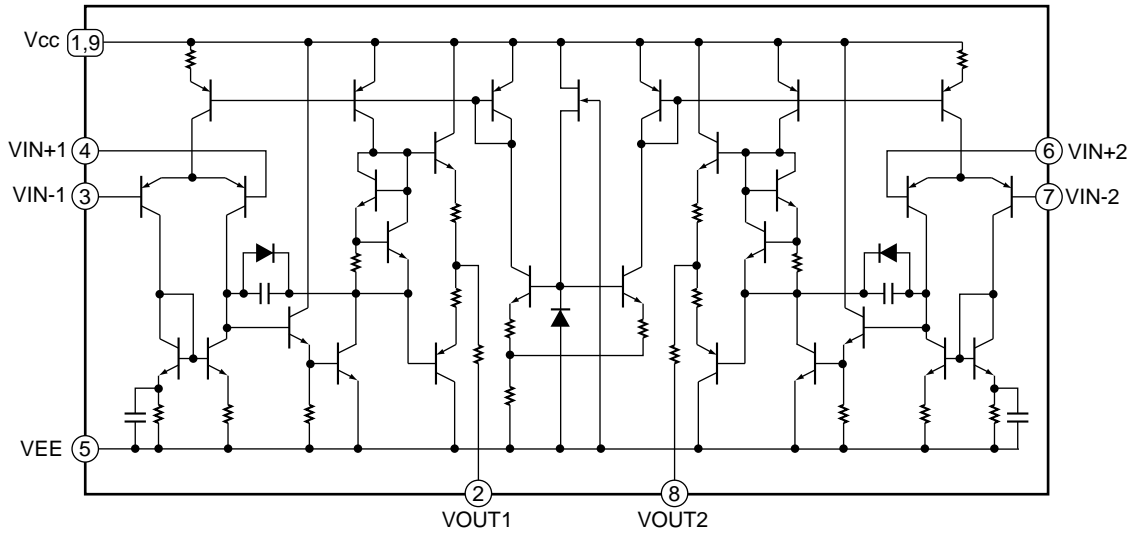

8. PANEL FACILITIES AND SPECIFICATIONS

• FRONT PANEL FACILITIES

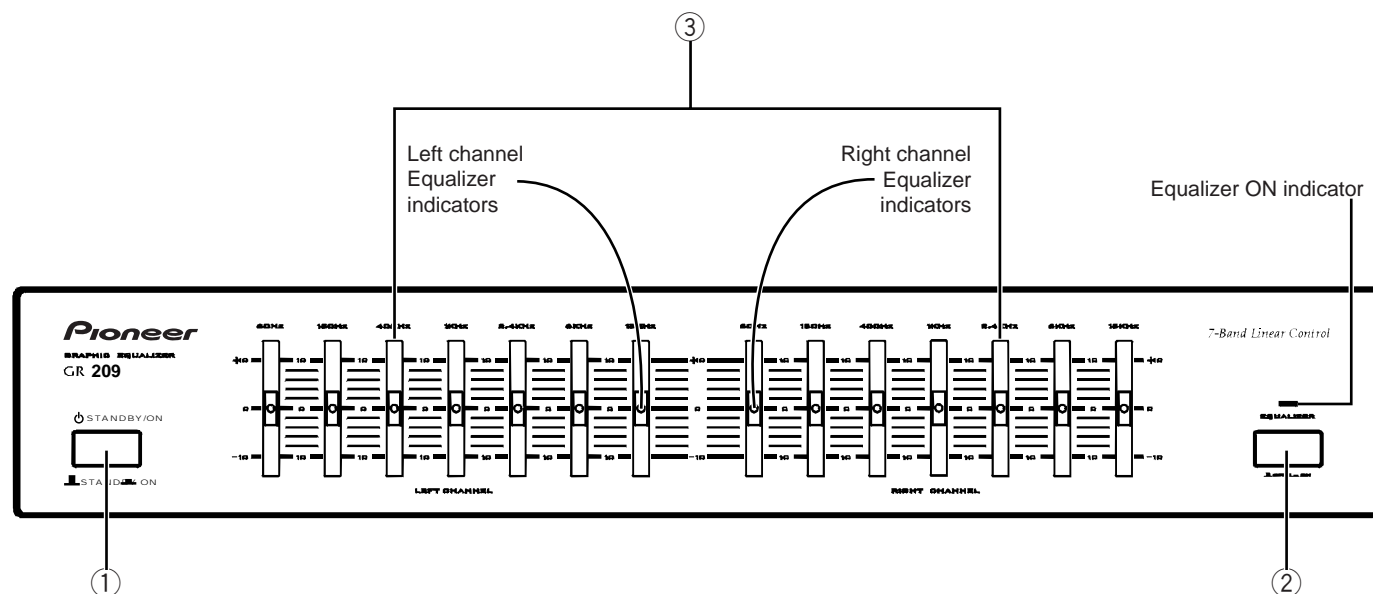

① STANDBY/ON switch (STANDBY / ON)

When this switch is set to the ON position, power is supplied to the unit's main circuits (Equalizer indicator lights).

NOTE:

Even when performing playback without using the functions of this component, be sure that its STANDBY/ON switch is ON. If the STANDBY/ON switch is STANDBY, no sound will be produced from the speakers.

② EQUALIZER button (EQUALIZER OFF / ON)

When this button is pressed, the equalizer ON indicator lights and its functions become operative. When pressed once again, this indicator goes out and the unit's functions are turned OFF. Use this button in the following manner:

- ON: When using the equalizer to add sound compensation while performing mixing operations with program sources (FM broadcasts, CD play, tape playback, etc.).
- OFF: When not using the equalizer, but playing back or recording program sources without compensation.

③ Equalizer controls

These are equalizer controls for the bands 60 Hz, 150 Hz, 400 Hz, 1 kHz, 2.4 kHz, 6 kHz and 15 kHz.

When the equalizer button has been set to ON, these controls may be adjusted. When a control is raised upwards from the "0" position, the frequency band corresponding to that control will be emphasized; when the controls is lowered, the frequency band will be attenuated. These controls can be used independently for right and left channels.

NOTE:

In order to protect your speakers from damage resulting from excessively large inputs, whenever augmenting high-frequency sound over a wide range, be sure not to raise your amplifier's sound volume too high.

• SPECIFICATIONS

Input terminals (Reference input level/Input impedance)
 INPUT 150 mV/50 kΩ
 Gain -2 dB
 Output terminals
 (Reference output level/Output impedance)
 OUTPUT 150 mV/3.3 kΩ
 Harmonic distortion (20 Hz ~ 20 kHz, Output 1V)
 0.03 %
 Frequency response
 INPUT 20Hz~20kHz⁺⁰₋₃dB
 Equalizer bands
 Center frequencies
 60 Hz, 150 Hz, 400 Hz, 1 kHz
 2.4 kHz, 6 kHz, 15 kHz
 Variable range ±10 dB
 SN ratio (IHF, A network, short circuit, 1V)
 INPUT 106 dB

Electrical section, miscellaneous

Power requirements (MYmodel) ... AC 220-230 V, 50/60 Hz
 (SD model) AC 110/120-127/220/240 V, 50/60 Hz
 Power consumption 6 W
 External dimensions (W x H x D) 420 x 85 x 214 mm
 16-9/16 x 3-3/8 x 8-7/16 in.
 Weight 2.2 kg (4 lb. 14 oz.)

Accessories

Pin-plug cords 2
 Operating Instructions 1
 Plug adaptor (SDXCN1 model) 1

NOTE:

Specifications and the design are subject to possible modifications without notice, due to improvements.

